

Plan

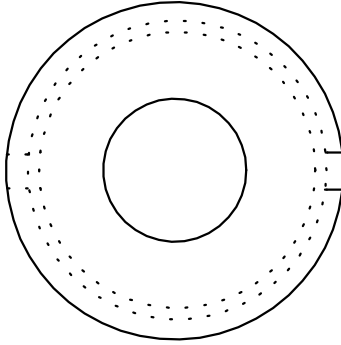

Elevation

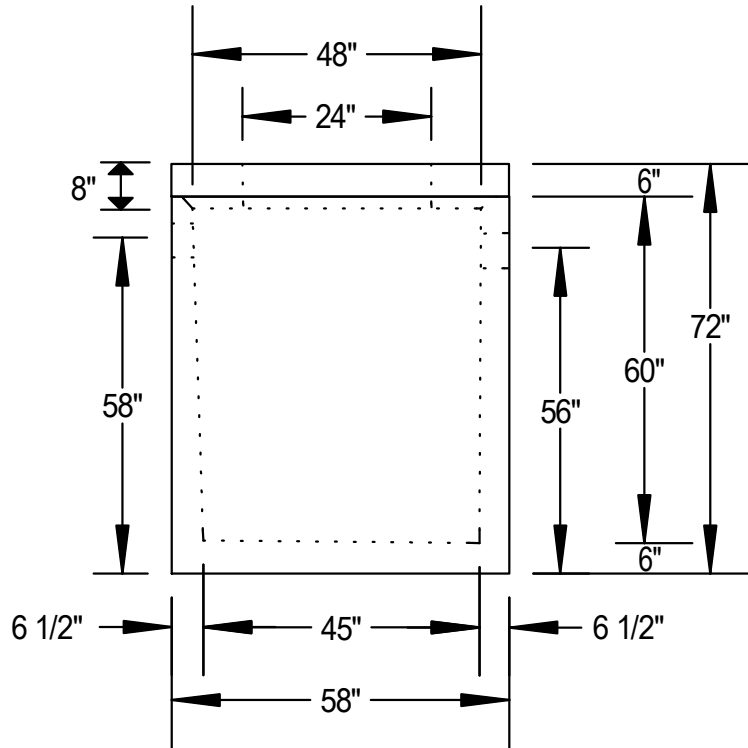

Notes:

Reinforcing Meets ASTM C-478.

Weight: Monolithic Bottom 7,500 lbs., Cover 1,800 lbs.

Lifting Plan: Bottom Use 3 Utility Anchors (P-75) & Insert Cover 3 Handles (Recon-2).

Upon Request Available With 2- 4"/3" High Pressure Boots.

5,000 P.S.I. Minimum Strength Envirocore Concrete.

We Produce A Green And Environmentally Friendly Product.

Model # 11130

Copeland Enterprises Inc.
 904 South Lipan
 Denver, CO 80223

48" Sump Pit
 With Insert Cover
 No Scale Page 19